

Fireray® 3000 Exd

Flameproof Optical Beam Smoke Detector



The Fireray® 3000 Exd is ideally suited for the protection of large areas, with potentially explosive atmospheres, against smoking fires. Fireray® 3000 Exd comprises an infrared transmitter and a receiver, both of which are ATEX-certified for use in Class I Div 1 Group 2 hazardous areas. There is a separate, safe area, wall-mounted remote/low level control unit to allow adjustment and testing from a convenient non-hazardous location.

The product is designed for large enclosures within oil rigs, refineries, ordnance stores and similar premises. It provides an early warning of smouldering or strongly smoke-generative fires, which may not be picked up by flame detectors installed in many hazardous areas.

Features

- Separate transmitter and receiver unit certified to Exd
- Allows for 2 Detectors per System Controller
- Range 5 to 100 metres, (16.4042ft to 328.084ft) configurable per set of Detectors
- Integral Laser Alignment in Receiver
- 2-wire Interface between Controller and Receiver
- Separate Fire and Fault Relays per Detector
- Remote/low Level Controller with LCD display (Safe Area)
- Programmable Sensitivity and Fire/Fault delay
- Automatic Gain Control (AGC) for drift compensation
- First Fix concept for Transmitter, Receiver and Controller
- Multiple cable gland knockouts for ease of wiring
- Transmitter can be powered from Controller
- Complies with ATEX and EN54:12
- Light Cancellation Technology

Approvals:

The Fireray® 3000 Exd complies with the ATEX directive.
 II 2GD IP66 Ex d IIC T5 Gb
 Ex tb IIIC T95°C Db



Operation

The Transmitter head emits a narrow beam of infra-red light to an associated Receiver head. Once smoke crosses through and thus obscures the IR beam path, the signal strength at the Receiver drops below a preset level which in turn results in an alarm condition.

The Fireray® 3000 Exd has been designed so that it can be installed by one operator, with its laser assisted alignment method combined with easy to use alignment LEDs offering visual feedback. Integrated laser alignment aid can be activated at the Controller.

The Fireray® 3000 Exd also has a feature which allows for the Transmitter to be powered from the Controller by wiring directly, thus reducing the number of power supplies required.

The low level Controller incorporates a LCD display, which offers a full icon-based, easy-to-use interface unit. This Controller enables ease of commissioning, testing and maintenance of the beam detection system. During commissioning the detector's fire sensitivity thresholds can be selected, along with the user variable time to fire and time to fault settings.

The system is fully compliant with the requirements of RoHS and WEEE.

Technical Specification

Operating Range:	5 to 100m (16.4042ft to 328.084ft)
Operating Voltage Range:	12 to 36V DC ±10%
Operating Controller Current (with 1 or 2 Receivers):	14mA (constant)
Operating Transmitter Current:	8mA (per Transmitter)
Power Down Reset Time:	>20 seconds
Fire and Fault Relay Contacts:	VFCO 2A @ 30 Volts DC resistive
Operating Temp. (non-condensing):	-10°C to +55°C (14f to 131f)
Optical Wavelength:	850nm
LED Indications:	
Control Unit -	Red = Fire Amber = Fault Green = System OK
Receiver -	Alignment LEDs for single person alignment.
IP Rating:	IP54 (Controller) IP66 (Transmitter/Receiver)
Relative Humidity (non-condensing):	93%
Housing Material	
(Controller):	UL94 V2 PC
(Transmitter/Receiver):	Copper Free Aluminium Alloy LM25, red
(Bracket):	Steel, red
Cable Gland Entries:	3 x 20mm
CPD Reference:	0786-CPD-21162

All figures are quoted for 25°C

Alarm & Operation Thresholds	Min	Type	Max
Delay to Alarm/Fault (selectable in 1 sec steps):	2s	10s	30s
Laser Time-out (selectable in 1 min steps):	1 min	5min	59min
Response Sensitivity/Threshold (selectable in 1% steps):	25%	35%	60%

Weight

Control Unit:	606g (21.37602oz)
Transmitter & Receiver (Inc. Brackets):	3.7kg (8lb 2.513670oz)

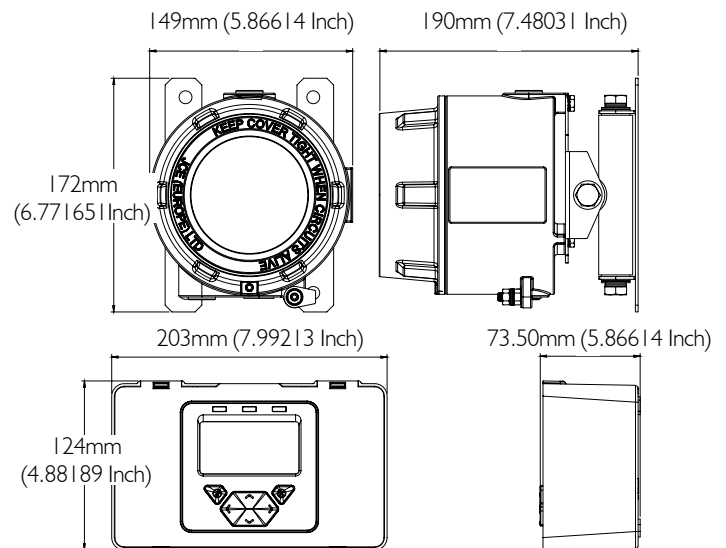

Installation Recommendations

Please refer to our User Manual for mounting and wiring instructions. The installation of Talentum® flame detectors should be undertaken in accordance with recognized national or international standards and codes of practice.

Ordering Information

3000-115	Fireray 3000 End to End smoke detector Exd 16.5ft. to 393ft. (5m to 120m). System includes 1 x Transmitter, 1 x Receiver, 1 x System Control Unit, 1 x Fixing Kit, 2 x Brackets
3000-026	Additional Detector Pack includes 1 x Transmitter, 1 x Receiver, 1 x Fixing Kit, 2 x Brackets
3000-209	Fireray 3000 Controller Back Box

Specifications and wiring information are provided for information only and are believed to be accurate. FFE Ltd assumes no responsibility for their use. Data and design are subject to change without notice. Installation and wiring instructions are shipped with the products and should always be used for actual installation. For more information, contact your Sales Representative.

Document Part No: 24-0125
0627



US Sales and Distribution
FFE Limited
1455 Jamike Ave Ste 200
Erlanger
KY 41018-3147
USA

t +1 859 957 1570
f +1 972 534 1526
e america@ffeuk.com
w www.ffeuk.com